

Axis Timber Bed Frame

Build your Bed Frame in 6 easy steps

What's in the box?

Before you start, lay out all parts so you're familiar with them.

1 /3

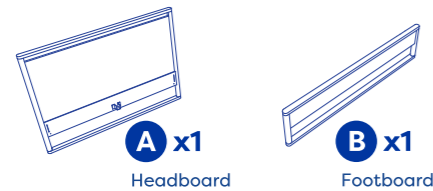

2 /3

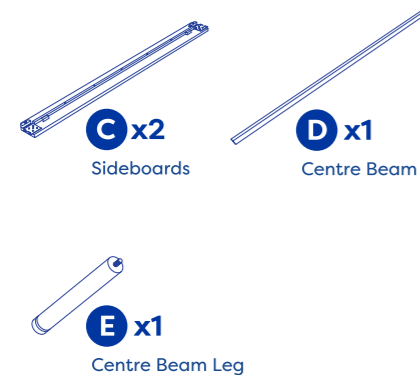

3 /3

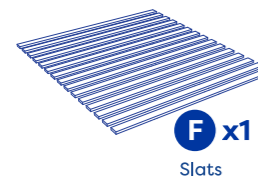

1

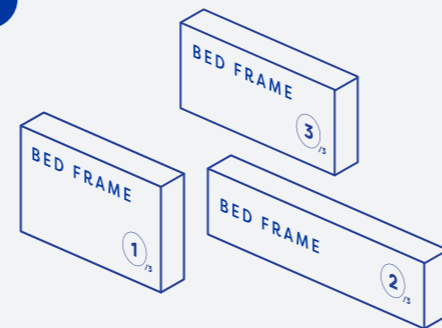

Your Axis Bed Frame comes in 3 boxes. First, double-check all boxes are for the correct bed size, and each box contains all items as listed.

2

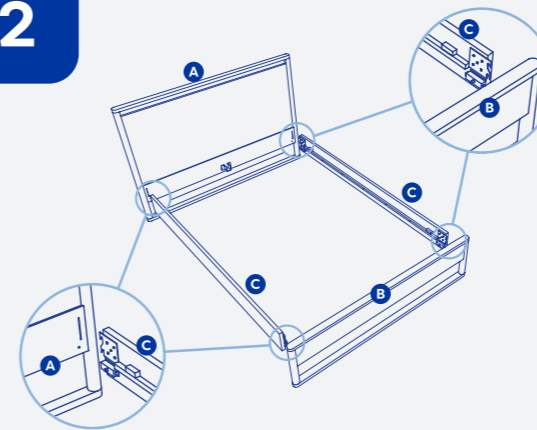

Attach the sideboards (C) to the headboard (A) and footboard (B) by inserting the connector on each sideboard into the hardware groove near the bed legs.

3

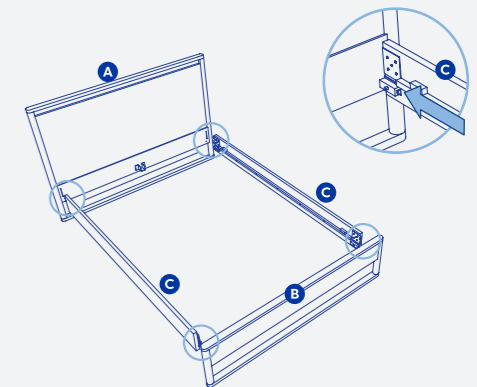

Once all panels are attached, secure them in place by pushing in the lock bar on the side of each panel.

4

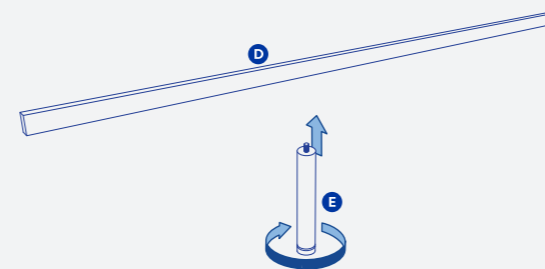

Screw the centre beam leg (E) into the centre beam (D). Adjust the leg by winding the pad at the base, so it just touches the floor. Don't make it too long or it might break.

5

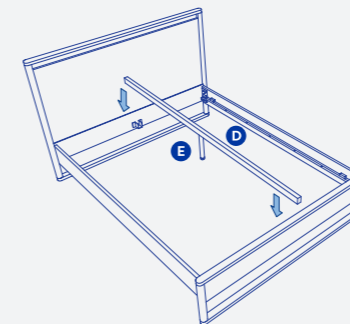

Connect the center beam (D) to the headboard and the footboard by sliding into the centre beam holders.

6

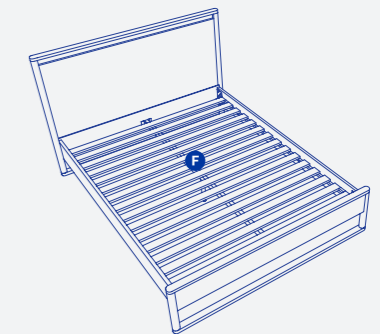

Place slats (F) on the frame. Ensure the slat holders sit snug between the last two slats at each end – that's it!